



Keypad Controller (BZ300)

Quick Start Guide

Compatible with Schlage Omnia
and Schlage eGO Smart Locks



Schlage Keypad Controller (BZ300)

Model:	Schlage Keypad Controller (BZ300)
Dimensions:	79mm x 125mm x 15mm
Material:	Aluminum frame / Tempered glass panel
Communication:	Bluetooth 4.1
Stand-by current:	≈15mA
Operating current:	≈1A
Power supply:	DC 12V
Unlocking time:	≈1.5S
Waterproof level:	IP66

Accessories



Keypad
Controller x 1



Mounting Plate x 1
Screws 4 + 1



Manual x 1



Hex Key x 1

Installation

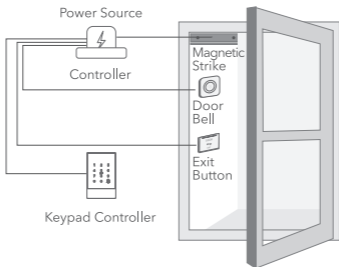

1 Drill a hole for the cable

Drill a hole at the appropriate position to make space for the cable to connect to the power source.

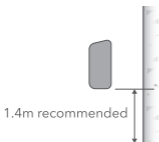

2 Install the mounting plate

Remove the mounting plate from the Keypad Controller and fix it on the wall with the 4 screws provided.

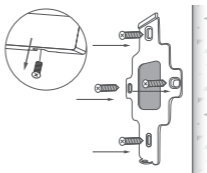

3 Wiring

Connect the leads to the appropriate ports of the power supply according to the diagram.

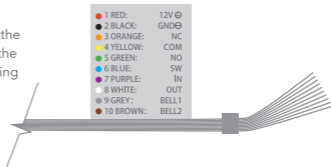

Full process control example

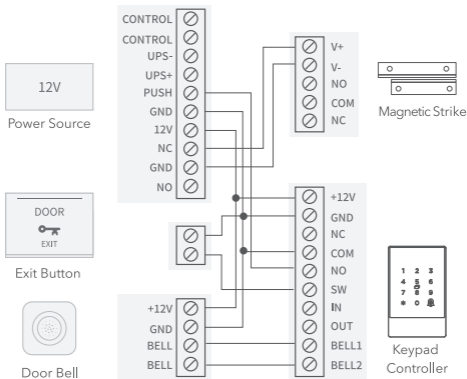

4 Install the Keypad Controller

Fit the Keypad Controller into the hook and fix it to the mounting plate with the screw in the bottom.

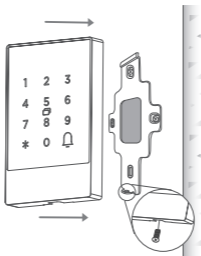

Pair the Keypad Controller with the Schlage Breeze app

- 1 Tap the panel to activate the lights on the keypad.



- 2 Tap the '☰' icon on the upper left corner, tap '+Add Lock', tap 'next'.



- 3 Tap the device shown on the screen. Wait a few seconds for pairing to complete.

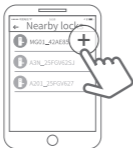

Warranty

The Schlage Keypad Controller (BZ300) has a one year warranty.

Our goods come with guarantees that cannot be excluded under the local consumer law. You are entitled to a replacement or refund for a major failure and for compensation for any other reasonably foreseeable loss or damage. You are also entitled to have the goods repaired or replaced if the goods fail to be of acceptable quality and the failure does not amount to a major failure.

Disclaimer

We continuously optimise products as new technologies and features are developed. For this reason, we reserve the right to make alterations to the products without prior notice.

Australia

1800 098 094

info.au@allegion.com

www.allegion.com.au

New Zealand

0800 477 869

nzinfo@allegion.com

www.allegion.co.nz

South East Asia

+65 6488 2562

sea.info@allegion.com

www.allegion.com

For more information visit

allegion.com.au/omnia or **allegion.co.nz/omnia**



ALLEGION

PDSC0057